

Toyota Motorsport

Doubling design productivity with V5 PLM

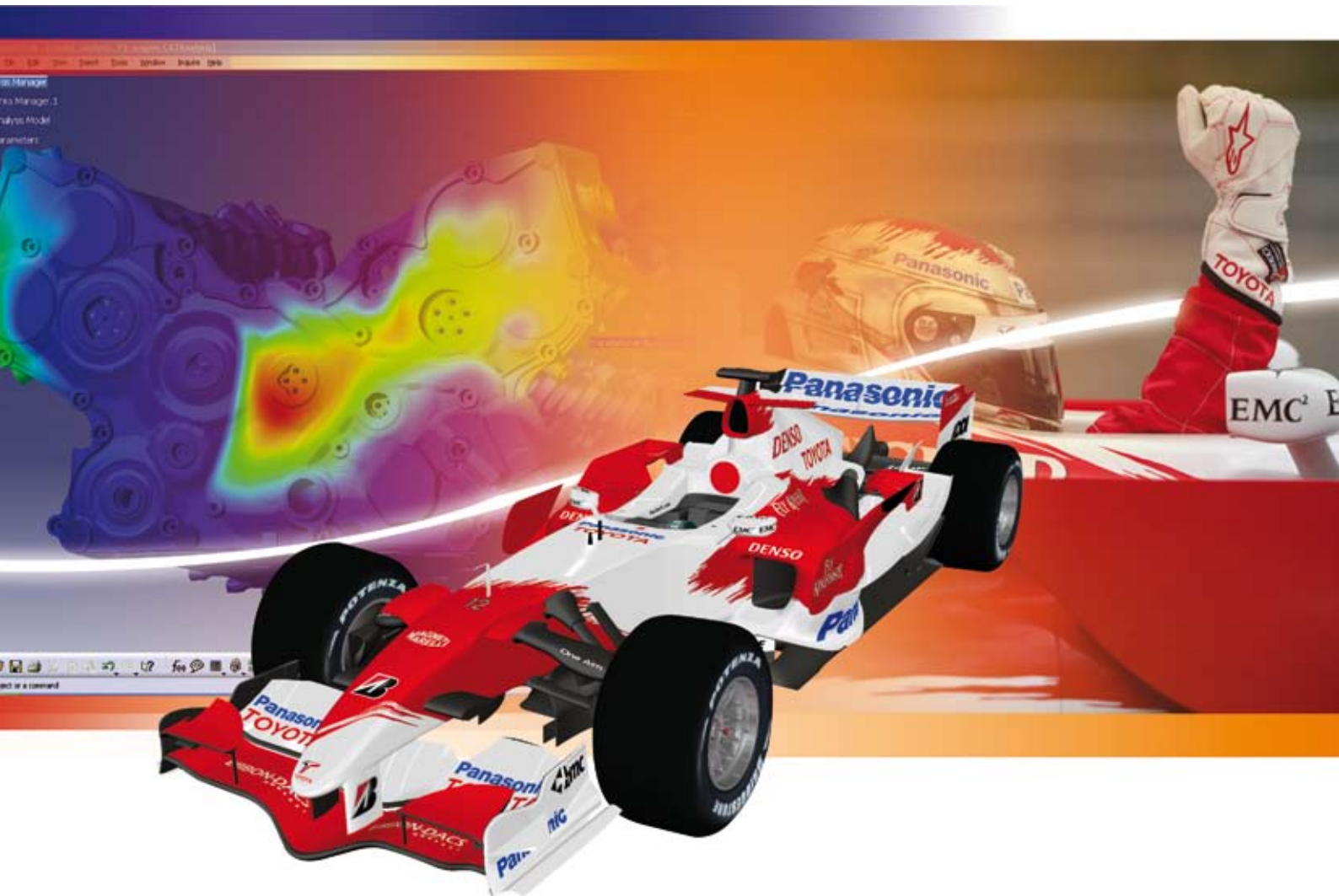



Toyota Objectives

- **Optimize car performance by designing and testing more car components between F1 bi-weekly races**
- **Comply with evolving FIA* regulations**
- **Reduce development costs by optimizing processes**
- **Implement Toyota's Kaizen philosophy of continuous improvement**



“Toyota Motorsport GmbH has one clear goal which is to be world champion. To achieve this, we need to continuously improve the development of the F1 car to reach the highest performance on the track.”

Tadashi Yamashina, Chairman and Team Principal, Toyota Motorsport GmbH

Company Overview

Panasonic Toyota Racing is the official name for Toyota's Formula 1 Team. Established in 2001, the team is run on behalf of Japan's Toyota Motor Corporation by Toyota Motorsport GmbH. 2007 is Toyota's sixth season in Formula 1, making it one of the youngest teams on the grid.

With more than 600 staff from 32 different nations, Toyota Motorsport has developed its complete Formula 1 car – chassis and engine – from scratch under one roof at its factory in Cologne, Germany. Toyota's long-term goal is to beat the more established teams in Formula 1 and become world champion.

Business Challenges

Toyota Motorsport GmbH was created to strengthen awareness and the image of Toyota Motor Corporation. Its purpose is to demonstrate to a large public that Toyota is a cutting-edge brand determined to attain its “One Aim” goal: to be number one. To that end, Panasonic Toyota Racing must win races and ultimately the Constructors' Championship to gain media exposure. This means that for each and every race, Toyota Motorsport GmbH must provide its two drivers with the fastest car possible, respecting the tight, two-week race schedule.

One of Toyota Motorsport GmbH's major business challenges is to quickly adapt car design to upcoming racing conditions, such as circuit configurations, driver racing style, and weather conditions. The team must also comply with seasonal changes in FIA* regulations. Moreover, the team practices Toyota's Kaizen philosophy of continuous improvement by always pushing the limits of technical innovation and reaching excellence in all domains. Finally, Toyota Motorsport GmbH must accomplish all of this within a defined budget, meaning controlling the cost of car development is also a priority.

*(FIA) Fédération Internationale de l'Automobile

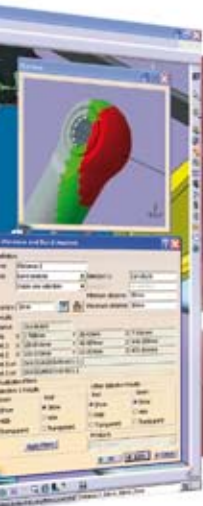

Solution

In order to address its business challenges, Toyota Motorsport GmbH chose Dassault Systèmes (DS) Version 5 Product Lifecycle Management (V5 PLM) solutions. “We needed a long-term PLM solution that covers our entire development process, as well as a partner capable of understanding our job,” said Thomas Schiller, General Manager, IT department, Toyota Motorsport GmbH.

CATIA V5 to optimize car performance

A crucial part of improving car performance involves getting the right part on the track rapidly. This is why the Design department uses CATIA V5 and its robust change management capabilities. For example, designers use CATIA V5's unique hybrid modeling capabilities that link mechanical and surfacic design in order to speed creation or modification of car components, as well as highly specialized modules such as CATIA Composites Design.

In addition, engineers appreciate CATIA V5's ease of use. “Designers say that they have fun working with CATIA V5!” said Markus Schwarze, Manager, IT Technical Applications, Toyota Motorsport GmbH.

SIMULIA to virtualize car tests

SIMULIA is Dassault Systèmes' solution for virtual testing. It includes ABAQUS and CATIA V5 analysis applications. Toyota Motorsport GmbH's chassis department uses ABAQUS for CATIA V5 to do complex calculations in the early stages of car parts development. “Thanks to the solver's flexibility and accuracy, ABAQUS FEA software is the standard tool used for calculations, non-linear engineering simulations and dynamic simulation of all chassis components,” added Markus Schwarze. CATIA V5 Analysis and ABAQUS solutions are also used in the engine department.

ENOVIA VPLM to streamline collaboration

To support its continuously evolving F1 car design, the Design office needs to manage all development data and make it instantaneously accessible to the entire team. ENOVIA VPLM provides the virtual product development environment where all designers, production, and track teams share the more than 8,500 up-to-date car parts.

Focus on LMS Virtual.Lab Motion

LMS is a Dassault Systèmes engineering innovation partner which offers a unique combination of simulation software (LMS Virtual.Lab), testing systems, and engineering services.

Toyota Motorsport specifically uses LMS Virtual.Lab Motion, which offers a complete solution to:

- realistically simulate the dynamics of mechanical systems
- accurately determine the resulting internal dynamic loads and stresses
- simulate the dynamic performance of new designs long before committing to prototype testing





“Ultimately, when you win races, you win them in the design area. Getting new ideas into the car is key when you’re working on a two-week timeframe. That’s where Dassault Systèmes V5 PLM solutions are absolutely critical to our core functions.”

Pascal Vasselon, Senior General Manager Chassis, Toyota Motorsport GmbH

Moreover, ENOVIA VPLM links the Toyota Motorsport GmbH virtual design to resources. “Thanks to the openness of ENOVIA VPLM, we have an ERP interface. We automatically transfer all our master data and bills of material from ENOVIA VPLM to our in-house ERP system,” said Markus Schwarze.

Open V5 PLM ecosystem to fully cover virtual processes

Specialized applications from DS’s CAA V5 software partners meet specific design, manufacturing and simulation needs such as LMS Virtual.Lab Motion® for dynamic motion simulation and CENIT’s FasTRIM V5 Based product for automatic laser-cutting robots programming.

Results

Toyota Motorsport GmbH has achieved clear and tangible benefits from its V5 PLM implementation throughout its entire development process:

Chassis process: time gains

Excellence in racing car design is the result of tremendous homogeneity between the chassis and the engine. The V5 PLM Digital Mock-Up (DMU) tools, native to CATIA and ENOVIA, are critical to achieving this harmony. “By using V5 PLM DMU solutions, we can check the car’s assembly while we’re still in the design stage, because the designers are not designing in isolation,” said Pascal Vasselon, Senior General Manager Chassis, Toyota Motorsport GmbH. “We simply don’t see the problems that we used to have in terms of car’s first physical assembly. This could take previously maybe two or three weeks. We now do it in two or three days. This time gain is a tremendous advantage for us.”

Aerodynamics process: productivity gains

The aerodynamics team, part of the chassis department, has a specific objective: design and test a maximum number of wind tunnel prototypes to find the optimal car component. “Moving from CATIA V4 to CATIA V5 has enabled us to almost double the number of prototypes we can make in a given time,” said Pascal Vasselon. “This in turn enables us to double the number of tests in the wind tunnel and double the car aerodynamic performance. That’s absolutely essential to high performance on the track!”

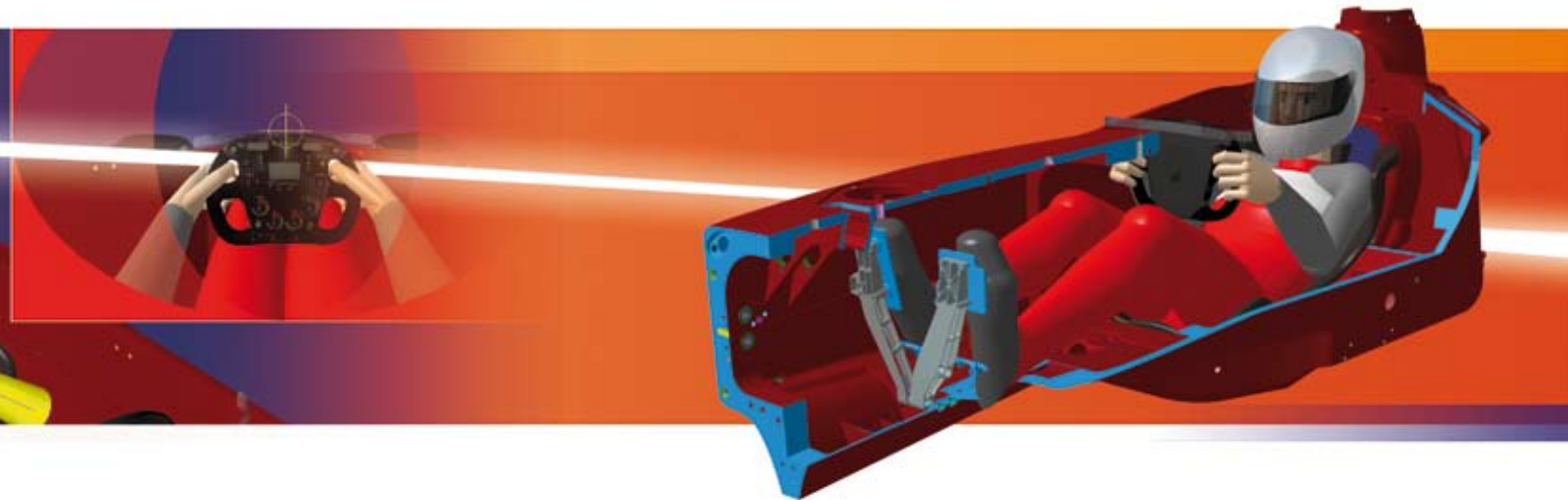

Another benefit measured by Toyota Motorsport GmbH's aerodynamics team comes from the implementation of the Generative Car solution. "The implementation of the Generative Car solution in the aerodynamics department has increased design productivity by 30%, and by up to 80% if we look at parts such as the front wing," said Stéphane Chosse, Wind Tunnel Model Design Manager, Aerodynamic department, Toyota Motorsport GmbH. "This was a real big step for us. It gave us the possibility to design quicker and therefore design more."

Toyota Motorsport GmbH is also implementing the CATIA V5 Composites Design solutions in the aerodynamics department. "The tests we made look very promising," said Markus Schwarze.

Engine process: design quality improvement

The powertrain challenge lies in producing the most powerful engine while keeping it as lightweight and reliable as possible. "Design quality is the key issue to a successful Formula 1 car engine," said Luca Marmorini, Senior General Manager Engine, Toyota Motorsport GmbH. "CATIA V5 analysis tools offer us the chance to simulate the constraints endured by extremely complex models, such as blocks or crankshafts. This definitely helps us increase the engine's design quality."

In addition, following the analysis simulation stage, the design modification phase is faster thanks to CATIA V5 knowledge-based architecture. It allows designers to capture design intent as well as easily modify parameters. Updating a part becomes almost instantaneous.

Car transmission process: time savings

Toyota Motorsport GmbH has made very significant time gains in the development of its car transmission since upgrading from CATIA V4 to CATIA V5. "CATIA V5 implementation in the transmission area was very impressive," said Thomas Schiller. "It took us the same time to implement, train people, and design the car transmission in CATIA V5 as it took us just to design it in CATIA V4. Plus, we were able to double design and analysis iterations!"

Cockpit ergonomics: innovation in F1 conductivity

Formula 1 drivers perform in a very stressful environment where cornering exerts forces between four and five G's (equal to a military jet cockpit).

V5 PLM Key Benefits

Time reduction

- 80% time in the aerodynamics design process (Generative Car solution)
- 90% time for the first physical assembly of the car - from three weeks to two days thanks to V5 PLM DMU
- 15%* time to create Bills of Material (BOM)

Improved car performance

- 100% increase in number of wind tunnel prototypes thanks to Knowledge-based designs
- One of the most reputed F1 engines

Costs Reduction

- 60%* costs and time spent searching for information during design processes
- 40%* cost for fixing BOM errors
- 48%* cost for administering Engineering Change Requests
- 57%* labor costs to complete ECRs

*Findings based on an independent study performed by PLM consultancy CIMdata

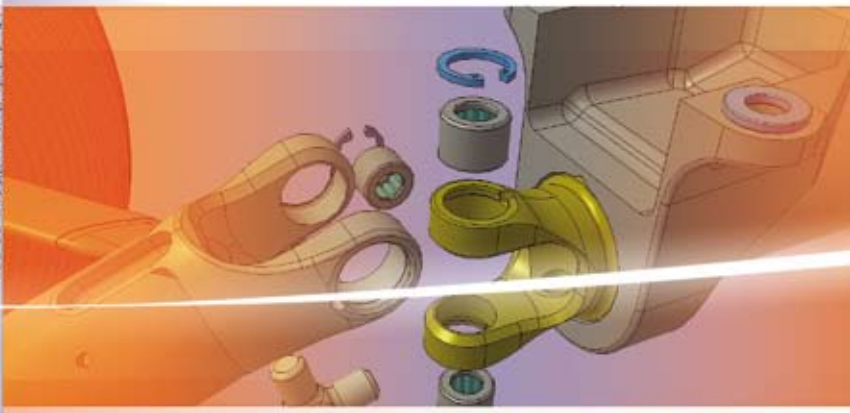
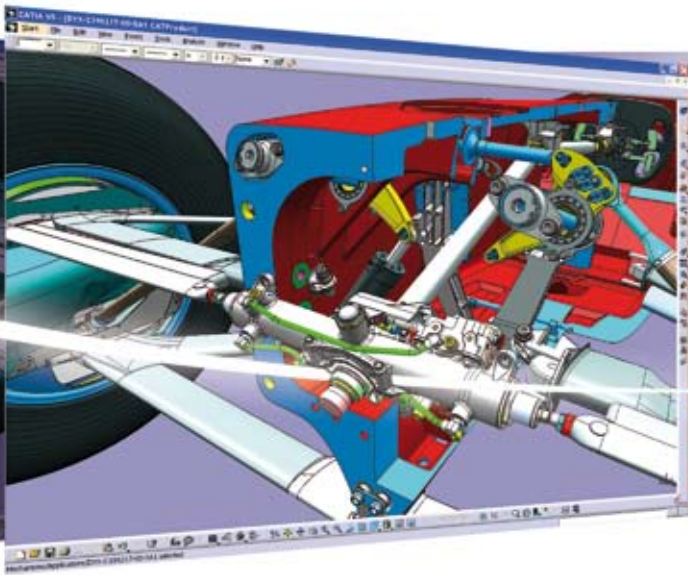

“Reliability is a serious issue in Formula 1. We need a very flexible system to modify and update parts. Dassault Systèmes V5 PLM solutions help us to be really aggressive.”

Luca Marmorini, Toyota Motorsport GmbH

To focus on performance, the driver must be in the safest and most comfortable position. CATIA V5 enables engineers to design the cockpit in order to optimize driver-car interaction.

“With CATIA V5 Human Modelling ergonomics tools, we insert the pilot virtually into the digital mock-up of the car,” said Pascal Vasselon. “We can then optimize the ergonomic design of the monocoque to ensure that the driver will fit perfectly and be able to operate the car while driving it at the limit.”

Extended collaboration around the digital mock-up

With CATIA V5 and ENOVIA VPLM, Toyota Motorsport GmbH has a virtual Formula 1 development hub where any team member can access the car’s digital mock-up. For instance, every person on the shopfloor and in the assembly workshop uses V5 PLM DMU tools to see in 3D the parts they have to produce.

In addition, the car’s digital mock-up can be accessed by the purchasing or marketing departments in order to perform specific tasks in CATIA V5. “In our marketing department, we use CATIA V5 Real Time Rendering to get an idea of what the car will look like before we build it,” said Markus Schwarze. “It is absolutely essential for our sponsors to see what millions of people will see on TV screens before the car is on the track.”

Furthermore, the digital mock-up enables Cologne-based engineers to collaborate with the parent company Toyota Motor Corporation in Japan on the design and manufacture of particularly complex parts.

Toyota Motorsport GmbH now supplies another F1 team with its renowned V8 engine. The 3D digital mock-up and the associated V5 DMU tools allow both teams to collaborate and optimize the V8 integration into the other team’s car chassis.

Finally, V5 PLM solutions are present on the circuits. “By using CATIA V5 and ENOVIA VPLM, the track mechanics are able to see, in 3D, how they have to fit all the car components,” said Pascal Vasselon.

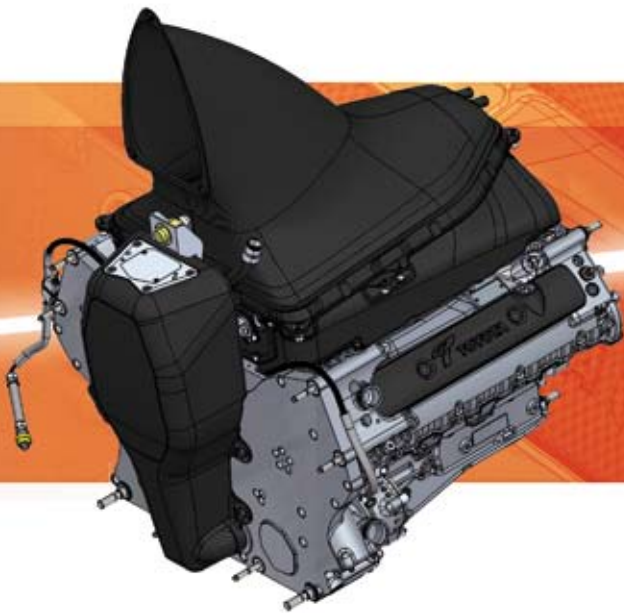

Future

In order to support its Kaizen philosophy, Toyota Motorsport GmbH will continue to enhance its use of V5 PLM solutions.

Toyota Motorsport GmbH is investigating these CATIA V5 products: CATIA Functional Molded Parts 2 (FMP) in the engine department for designing cast and forged parts with an unmatched productivity and flexibility; and CATIA V5 Electrical design solutions in the engineering department for designing electrical harnesses within the context of the 3D digital mock-up.

In addition ABAQUS Standard, from SIMULIA, will complete the composites design-to-manufacture process.



“We view all partnerships, and in particular the one we have with Dassault Systèmes, as a win-win opportunity. Dassault Systèmes offers us car development solutions that give us the cutting-edge performance that is required in Formula 1. At the same time, we like to think we’re pushing their technology to new limits because of the ultimate challenge of material and performance that Formula 1 demands.”

John Howett, President, Toyota Motorsport GmbH

V5 PLM for the Automotive Industry

DS has been working with major automotive manufacturers and suppliers for more than 20 years to provide a range of leading PLM solutions.

Built from industry experience and addressing all key automotive development domains, Generative Car Solutions combine the best of Dassault Systèmes’ CATIA V5, DELMIA, ENOVIA and SIMULIA products with dedicated automotive best practices.

Fostering the capture, sharing and reuse of company knowledge while optimizing the end-to-end process from concept to maintenance, DS Generative Car Solutions help automotive manufacturers and suppliers to considerably reduce design cycle time and increase productivity, profitability, and rapid return on investment.

For information about DS Generative Car Solutions, visit www.3ds.com

The Dassault Systèmes home page can be found at www.3ds.com

Dassault Systèmes
9, quai Marcel Dassault
BP 310
92156 Suresnes Cedex
France

As a world leader in 3D and Product Lifecycle Management (PLM) solutions, the Dassault Systèmes group brings value to more than 90,000 customers in 80 countries. A pioneer in the 3D software market since 1981, Dassault Systèmes develops and markets PLM application software and services that support industrial processes and provide a 3D vision of the entire life cycle of products from conception to retirement.

Dassault Systèmes develops and markets PLM application software and services that support industrial processes and provide a 3D vision of the entire lifecycle of products from conception to maintenance.

The Dassault Systèmes V5 PLM offering consists of CATIA V5 for designing the virtual product, DELMIA for virtual production, ENOVIA for global collaborative lifecycle management (including ENOVIA VPLM, ENOVIA SmarTeam, and ENOVIA MatrixOne), and SIMULIA for virtual testing.

CATIA®, DELMIA®, ENOVIA®, and SIMULIA® are registered trademarks of Dassault Systèmes or its subsidiaries in the US and/or other countries.

Images courtesy of Toyota Motorsport GmbH.

© Copyright Dassault Systèmes 2007.

All rights reserved.

RF_Y_Z3WKB_EN_200611

**For more information or to contact
a sales representative, visit
www.3ds.com/contacts**

**The LMS home page can be found at
www.LMS.com**

